

# 14SR



Concrete solutions. Always.

**Engine D722**

**Engine power 8,8 kW - 11,8 HP**

**Transport weight 1.255 kg**

 **EUROCOMACH®**

# 14SR

Transport weight with canopy (without bucket and operator)	kg	1.255
Transport weight with canopy and FOPS roof (without bucket and operator)	Kg	1.280
Operating weight ISO 6016 with canopy (with bucket 30 kg and operator 75 kg)	Kg	1.360
Operating weight ISO 6016 with canopy and FOPS roof (with bucket 30 kg and operator 75 kg)	Kg	1.385
Travelling speed	km/h	1a : 0 ÷ 1,8 / 2a : 0 ÷ 3,8
Slew speed	rpm	9,5

ENGINE		
Type	KUBOTA D722 - STAGE 5	
Max. Power (2.200 rpm)	kW - HP	8,8 - 11,8
Displacement	cc	719
Number of cylinders	n°	3
Cooling	Liquid	
Consumption	lt/h	1,8
Alternator	V (A)	12 (40)
Battery	V (Ah)	12 (45)

HYDRAULIC SYSTEM		
Pump type	variable flow	
Pump displacement	cc	5,5 + 5,5
Pump capacity	lt/min	28
Max. circuit calibration pressure	bar	200
Auxiliary system (max pressure): AUX 1 single or double effect	lt/min (bar)	28 (200)

PERFORMANCES		
Max. digging depth with standard arm (optional arm)	mm	2.045 (2.175)
Max. dumping height with standard arm (optional arm)	mm	2.290 (2.380)
Bucket breaking force (standard arm) ISO 6015	daN	1.150
Arm breaking force (standard arm) ISO 6015	daN	630
Traction force	daN	1.000
Specific ground pressure	kg/cm <sup>2</sup>	0,31
Max. slope	60% - 30°	

DIMENSIONS		
Maximum width	mm	790 - 1.050
Total height	mm	2.300
Rear rotation radius	mm	565
Digging arm length std (optional)	mm	1.020 (1.150)
Tracks width	mm	180
Rollers number (for each side)	n°	3

FILLINGS		
Fuel tank	lt	14,5
Hydraulic oil tank	lt	9,5
Hydraulic circuit capacity	lt	15
Cooling system capacity	lt	6
Engine oil	lt	1,8

CONTROLS	
Boom, dipper stick, bucket and turret swing	2 pilot joysticks
Track movements (included counter rotation)	2 pilot levers
Dozer blade	pilot lever
Auxiliary system with latch AUX 1 (single or double effect)	electroproportional switch on right joystick
Boom swing	electroproportional switch on left joystick

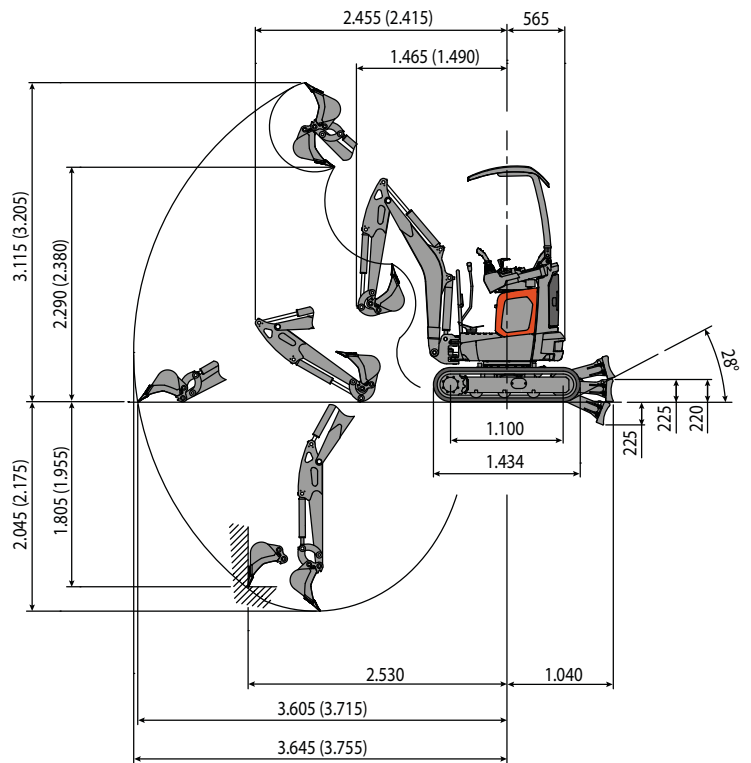

Standard dipper stick L=1.020  
Optional dipper stick L=1.150

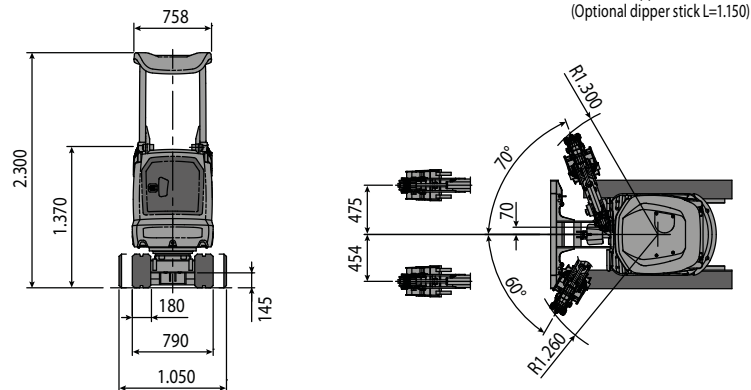

## LIFTING CAPACITY

Opening arm from the rotation's center (m)  
Lifting capacity (kg) at 1.0 m height

	2	3	MAX
Frontal and lowered dozer blade	*0,30	*0,15	0,14
Frontal and lifted dozer blade	*0,30	0,15	0,13
Lateral, open undercarriage	*0,28	0,14	0,11

\* Indicates the hydraulic load limit.

The lifting capacity is based on the ISO 10567 and it does not exceed more than the 75% of static tipping load or more than the 87% of the hydraulic lifting capacity of the machine.

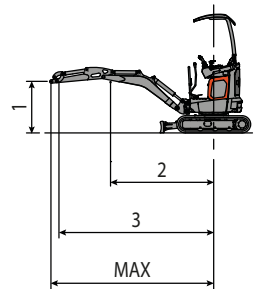

 **EUROCOMACH®**